

## S35-3E

1/8 Off Road Brushless Power Pro Buggy

Name: \_\_\_\_\_  
Date: \_\_\_\_\_  
Track: \_\_\_\_\_

**Diff. Oil**  
Front: # \_\_\_\_\_  
Center: # \_\_\_\_\_  
Rear: # \_\_\_\_\_

### Tire

Front: \_\_\_\_\_ Rear: \_\_\_\_\_  
Type: \_\_\_\_\_ Type: \_\_\_\_\_  
Foam: \_\_\_\_\_ Foam: \_\_\_\_\_

### Front Suspension

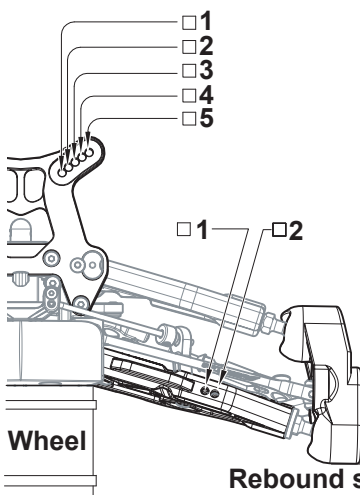

**Front Toe-In**

-1  
 0  
 +1

Al(11g) Brass(25g) Brass(35g)

-1  
 0  
 +1

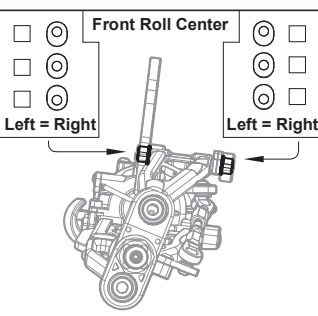

Track width \_\_\_\_\_ mm  
Camber angle Upper \_\_\_\_\_ mm  
Lower \_\_\_\_\_ mm  
Toe angle \_\_\_\_\_ mm  
Rebound stop \_\_\_\_\_ mm  
Sway bar  Use \_\_\_\_\_ mm  
 None

Wheel

Rebound stop

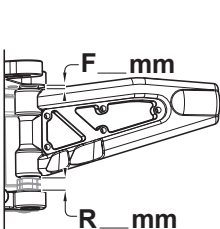

**Carbon Arm Covers:**  
F/Upper \_\_\_\_\_ mm  
F/Lower \_\_\_\_\_ mm

### Front Shock System

Oil: \_\_\_\_\_  
Pistons: \_\_\_\_\_  
Spring: \_\_\_\_\_  
Spacer: \_\_\_\_\_ mm

### Camber Angle

L: \_\_\_\_\_ °  
R: \_\_\_\_\_ °  
Notes: \_\_\_\_\_

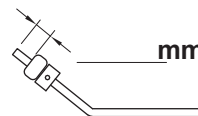

### Steering Ackerman

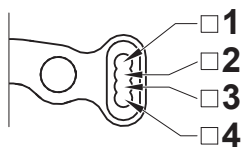

Body: \_\_\_\_\_

Wing: \_\_\_\_\_

### Rear Suspension

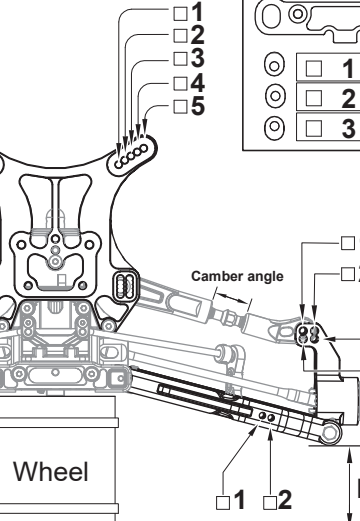

**Rear Toe-In**

1  
 2  
 3

3.0  
 2.0  
 1.0  
 30+1KUp  
 30-1KUp  
 20+1KUp  
 20-1KUp

### Upper arm position



Camber angle \_\_\_\_\_ mm  
Rebound stop \_\_\_\_\_ mm

### Wing Position

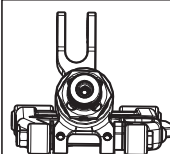
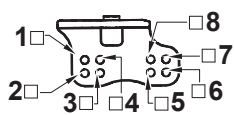

Wheelbase F \_\_\_\_\_ mm  
adjustment R \_\_\_\_\_ mm

### RearShocks

Oil: \_\_\_\_\_  
Pistons: \_\_\_\_\_  
Spring: \_\_\_\_\_  
Spacer: \_\_\_\_\_ mm

Sway bar  Use \_\_\_\_\_ mm  
 None

Wheel

Rebound stop

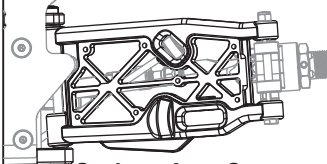

**Carbon Arm Covers:**  
R/Lower \_\_\_\_\_ mm

Notes: \_\_\_\_\_